

Aumer, Wolfgang; Schuffenhauer, Uwe; Herlitzius, Thomas; Lindner, Mirko; Geißler, Mike and Michalke, Norbert

Functional integration of an electrical drive in a threshing cylinder

A further increase of productivity and efficiency in harvesting combines will be necessary in the future. The requirements to increase machine performance within a limited space will create new drive concepts. With the example of the electrically direct driven threshing cylinder the potential for integration of electrical drives into functional elements is presented.

Keywords

Electrical drive, threshing cylinder, combine, driveline

Abstract

Landtechnik 65 (2010), no. 3, pp. 194-197, 5 figures, 1 table, 5 references

■ The productivity improvements in combines are characterised by the increase of maximum feedrate at given quality parameters, functional improvements in order to decrease specific power requirements and rising of the engine power. The engine power has been growing in average by 3 % per year for the last decade [1]. Combines for harvesting various crops have currently 150 to 470 kW engine power. A continuous increase of the productivity is difficult within a limited space and with conventional concepts.

The drivelines in combines are very complex. Much space is needed to transfer the power to the various drives. Electric drive systems can simplify the drivelines [2]. For the optimal space utilization, it is in particular advantageous to integrate high efficient and compact drives into the functional elements. Decentralized drives enable local intelligence. This means, drives have their own specific and independent control system that communicates with the vehicle management. Electric drives enable new strategies of driveline management (**figure 1**). With the available information, such as torque and speed, the power flow in the driveline can be monitored and controlled. Individual and continuous speed and torque controllability allow maximum flexibility of function and design of the driving elements [3; 4].

Function- and System integration of electrical drives

The power for the threshing cylinder, as shown in **figure 2** (left), is transferred from the power take off through a countershaft to the variator for the speed adjustment and eventually with a reduction gearbox to the cylinder. A high number of rotating parts accumulates a considerable active mass of about 500-1 000 kg. The efficiency of the mechanical driveline averages between 0.89-0.92.

A threshing cylinder with integrated electric direct drive was developed with the objective of system simplification at less space demand. **Figure 2** (right), right shows the electrical driveline for the threshing cylinder of a combine with more available space. The generator is connected directly with the engine. The generated electrical energy is controlled by an

Fig. 1

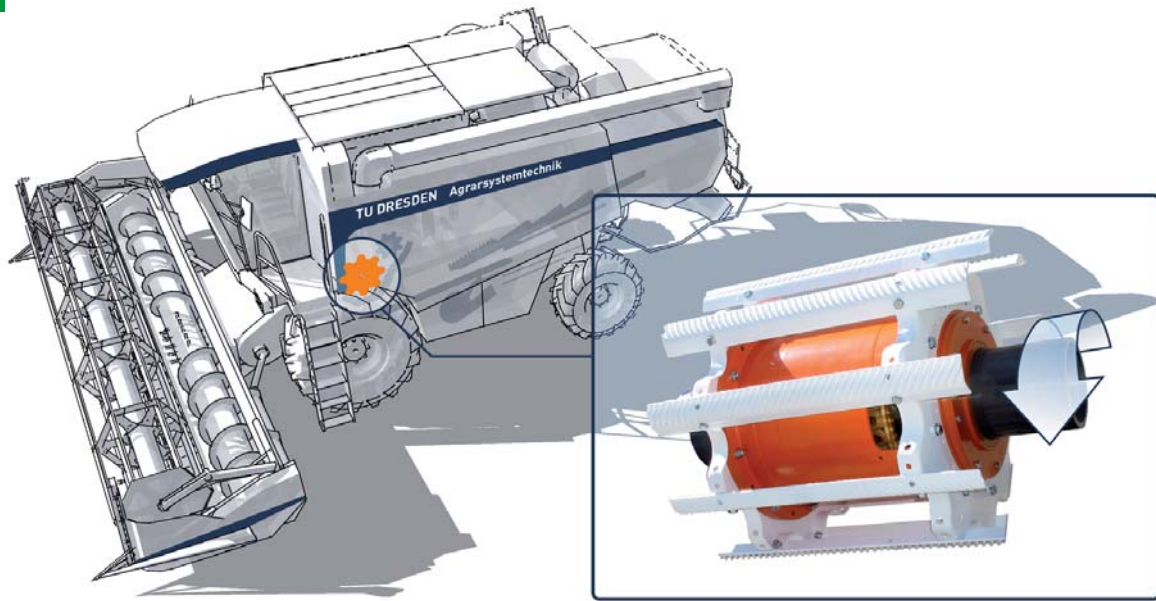

Electrified threshing cylinder in the combine

inverter with DC circuit and transferred to the electric direct drive of the threshing cylinder. A capacitor located in the DC circuit can absorb short term load peaks. On the test bench, the electric drive of the threshing cylinder was operated with stationary power electronics. For the upcoming application in the combine the electric motor and the inverter could be packaged within the threshing cylinder [5].

Technical characteristics of electric direct drives

The used motor is an individually designed and manufactured permanently synchronous motor with an outer rotor. Synchronous motors are rotating field motors, where the rotating field of stator and rotor rotate synchronously. A rotating field is

generated by the spatial configuration of the stator coils and the timing of the input current. Compared to asynchronous motors, permanently synchronous motors have a reduced mass at a higher efficiency. The synchronous motor has a smaller run-up time at no load due to the maximum motor torque and low inertia. Low inertia effects specifically in regards to the dynamic characteristics. The threshing cylinder with integrated permanently synchronous motor is shown in figure 3 as a cut-away model.

A permanently synchronous motor designed as an external rotor is integrated into the threshing cylinder. The external rotor transmits the torque and carries the rasp bars. Heat rejection is executed by an air stream going through the stator axle

Fig. 2

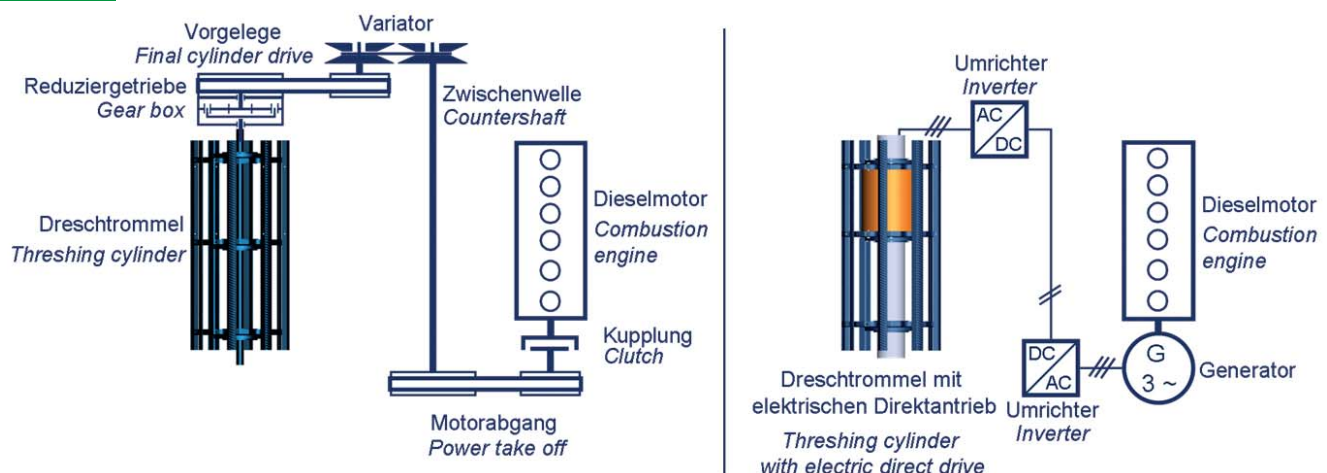

Mechanical (left) and electrical drive line for the threshing cylinder

Fig. 3

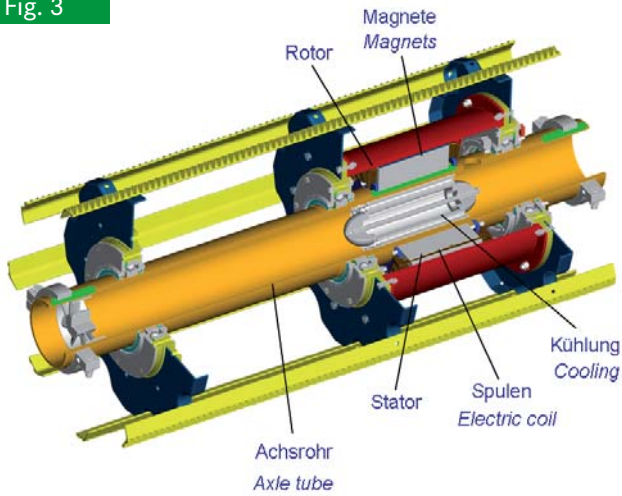

Direct driven threshing cylinder with permanently synchronous motor as external rotor

tube. The stator of the electric drive consists of the lamination stack and the stator winding. The rotor has the outer ring and the permanent magnets. The used permanent magnets are rare-earth material neodymium iron boron. These magnets provide excellent magnetic properties and can develop higher torque as ferrite magnets.

A constant torque is available up to the rated speed. The torque of the electric motor can rise short term up to multiples of its rated torque. In **table 1** the characteristics of the direct drive of the threshing cylinder are described.

Investigations with a load motor were carried out to determine the speed stiffness and thermal behaviour of the threshing cylinder. **Figure 4** shows the test bench.

The threshing cylinder and the load motor are mechanically coupled by a chain. The electric motor of the threshing cylinder is operated in speed control. The desired load is provided by

Fig. 4

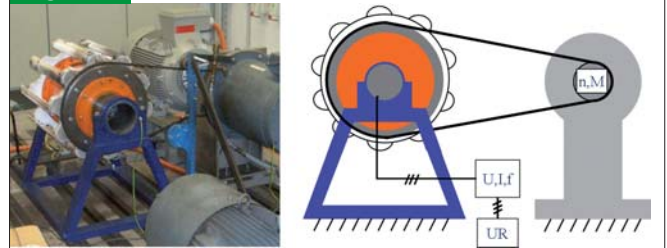

Test bench for the threshing cylinder

U: voltage; I: current, f: frequency, n: speed, M: torque, UR: inverter

the torque control of the load motor. **Figure 5** shows the test results of the electric direct drive for the threshing cylinder on the test bench.

The ability to operate the electric threshing cylinder with constant nominal torque from 0 up to the rated speed of 1000 min⁻¹ is shown by the torque-speed characteristic. **Figure 5** (above right), shows the speed stiffness independently from the load. It is characteristic for electrical drives that speed can be controlled independent from load, which is in case of the threshing cylinder an advantage for the performance and the quality of the separation at different feed rates. The speed is adjustable continuously and reversibly from 0–1500 rpm for the settings of various crops. The reversibility is also an additional feature. In **figure 5** at the bottom, the direct dependency from torque to stator current and frequency to speed, is shown. The power flow within the driveline can be monitored utilizing the available information of torque and speed. The inverter controls the speed or the torque of the threshing cylinder without additional sensors. In addition, the inverter can determine the mass moment of inertia and identify the electric motor. The control of the inverter is done via CAN bus, which integrates the electric drive system into the vehicle management.

Conclusions

Innovative individual concepts for hybrid drives embedded in a vehicle management in combines contribute to further increases of productivity and efficiency as needed. Task-specific, distributed electric propulsion systems with a modular design could be a promising alternative; an electric power system could provide the required power. Electric drives, which are integrated within functional elements, provide system simplifications by reducing the number of drive and transmissions elements. In a new system other decentralized drives can be also driven electrically. Functional and performance advantages of the separation and threshing process are expected due the speed stiffness of the electric motor. In addition to the reduced space requirements electric drives allow a simple design of drivelines in combines. Due to the intelligence of electrical drive systems the power flow in the driveline is known and can be controlled by CAN bus.

Table 1

Characteristic of the electric drive for the threshing cylinder with power electronic

Nennleistung Nominal power	62,5 kW	Nennstrom Nominal current	108 A
Nenn Drehmoment Nominal torque	597 Nm	Maximaldrehmoment Maximum torque	1200 Nm
Nenn Drehzahl Nominal speed	1000 min ⁻¹	Drehzahlbereich (reversibel) Speed range (reversible)	0-1500 min ⁻¹
Strangspannung Phase voltage	528,6 V	Frequenz bei Nenn Drehzahl Frequency at nominal speed	200 Hz
Pole Pole	24	Nuten Slots	27

Fig. 5

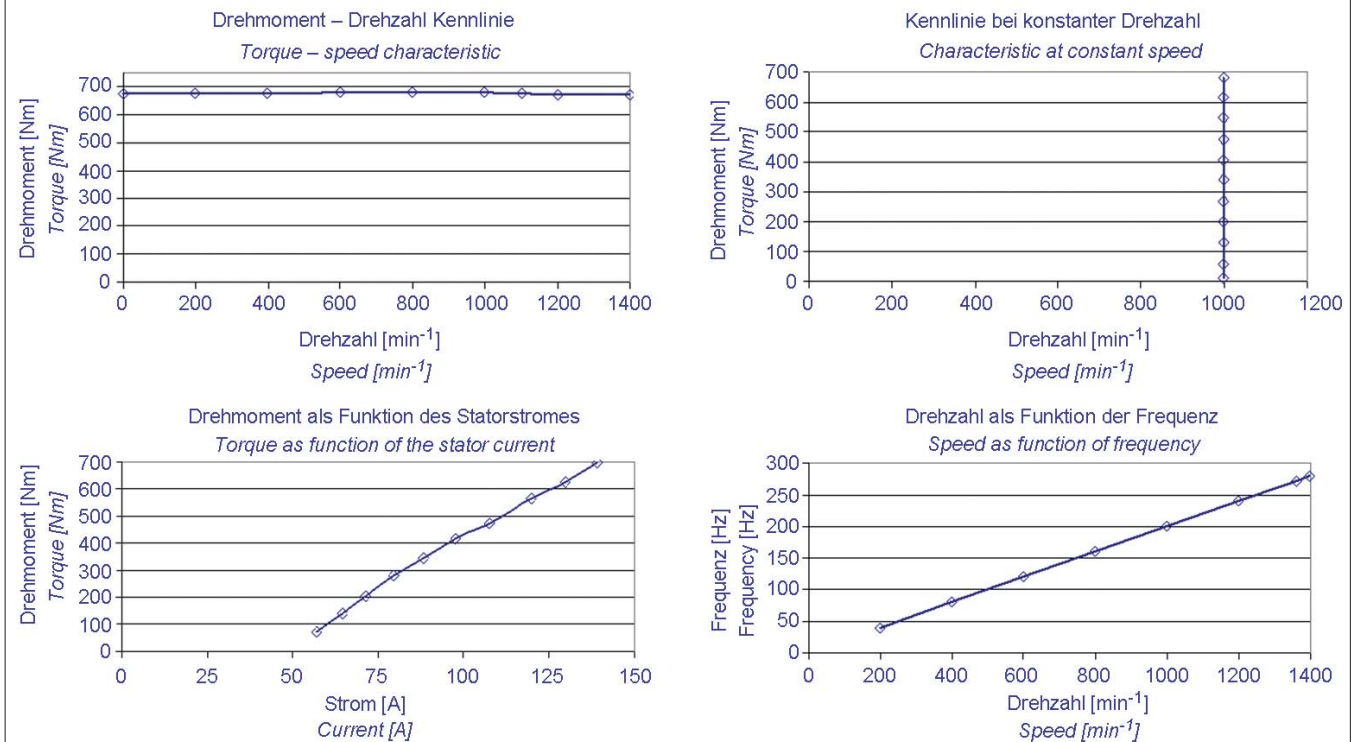

Results of the test bench

Literature

- [1] Nacke, E.: Ein Simulationsmodell zur Analyse der Einsatz- und Leistungsparameter von Erntemaschinen. Landtechnik 62 (2007), Sonderheft, S. 278–279
- [2] Aumer, W.; Th. Herlitzius, M. Geißler und M. Lindner: Diesel-elektrisches Antriebssystem in selbstfahrenden Landmaschinen. In: VDMA (Hg.): Tagungsband 4. Fachtagung Baumaschinentechnik, Dresden, 15.05.2009. Schriftenreihe der Forschungsvereinigung der Bau- und Baustoffmaschinen e. V. (FVB), Heft 37, 2009, Frankfurt
- [3] Herlitzius, Th.; Aumer, W., Lindner, M., Bernhardt, G., Schuffenhauer, U., Michalke, N. and Kuß, H.: System Integration and Benefits of Electrical Solutions in Mobile Machines. In: Tagungsband ECPE-Seminar: More Electric Vehicles, München 30.-31.03.2009
- [4] Rauch, N.: Mit elektrischen Antrieben Traktor-Geräte-Kombinationen optimieren. In: Tagung Land.Technik für Profis 2010. Traktor – quo vadis? Tagungsband, VDI-Verlag GmbH, Düsseldorf, 2010, S. 85–100
- [5] Eversheim, W.; J. Schernikau und R. Niemeyer: Mechatronik – Konsequenzen einer Technologieintegration. VDI-Zeitschrift Integrierte Produktion, Band 140 (1998) , H. 11/12, S. 24–26

Authors

M. Sc. Wolfgang Aumer, Dipl.-Ing. Mirko Lindner and Dipl.-Ing. Mike Geißler are researchers at the Professorship for Agricultural Systems and Technology (head: **Prof. Dr.-Ing. habil. Th. Herlitzius**), Institute of Processing Machines and Mobile Working Machines at the TU Dresden, 01062 Dresden, E-Mail: aumer@ast.mw.tu-dresden.de

Dipl.-Ing. Uwe Schuffenhauer is researcher in the department for electric engineering at the university of applied sciences , 01069 Dresden (head: **Prof.-Dr.-Ing. Norbert Michalke**).