

Georg Kormann, Zweibrücken, and Hermann Auernhammer, Freising

Continuous moisture measurements in self-propelled forage harvesters

Based on a well-known physical method of moisture content measurement, commercially available sensors were used in an attempt to integrate a harvest material moisture measuring system into a forage harvester. Basic laboratory investigations looked into the suitability of sensors in measuring organic material moisture content and field trials were carried out for direct comparisons between different systems.

In order to meet the demands from consumers' increasing quality awareness and the attempts of the European Union to achieve a guaranteed food safety, high-performance documentation systems are necessary. These should be able to record the complete production process of agricultural products. Yield mapping systems in combine harvesters can contribute a great deal towards such information gathering. For the forage harvester, on the other hand, the continuous determination of moisture content or material components represents a key technology within yield measurements.

Whilst combine yield mapping systems with moisture sensors on the market nowadays, moisture measurement in forage harvesters is only known from research reports [2, 3]. The high velocity flow of harvested material and its non-homogeneity represent high demands on sensors. Moisture content also has a clear effect on forage material density and knowledge of this parameter can improve the precision of any forage harvester volumetric mass flow measurement systems.

Basics

Bearing in mind [4] and [5] work on wet material measurement principles and the basic investigations of Ahlgrimm [1] we can in theory present the possibilities listed in table 1 for continuous moisture measurement in a forage harvester. At the same time the factors influencing the measurement principle in each case have to be identified.

Material and methods

As part of a cooperation involving John Deere and the specialist department Crop Production Technology at the TU Munich different moisture measurement principles were investigated for suitability for moisture measurement in harvested forage. Finally, the integration of the suitable moisture sensors followed into a self-propelled forage harvester so that it was possible to field-test the different principles in direct comparison.

The gathering of possible harvest materials from straw through grass and maize showed that the moisture range to be recor-

Table 1: Factors influencing the technically relevant moisture measuring systems

Measurement systems				Microwavemeasurement system			Infrared measurement system				
	Conductivity measurements	Dielectric measurements	Capacitance measurements	Transmission	Reflection	Resonator	Time area reflection	Transmission	Reflection	Nuclear resonance system	Nuclear radiation system
Influence factors											
Material temperature	2	2	2	2	2	2	2	1	1	4	4
Material density	2	1	1	2	2	2	2	1	4	3	2
Layer thickness	2	2	2	2	4	2	2	1	4	3	2
Corn size	2	2	2	2	2	2	2	2	3	2	2
Sensor pressure	2	2	2	4	4	4	4	3	3	2	4
Material homogeneity	1	1	2	3	1	3	3	3	3	3	2
Elektrolyte content	1	2	3	3	3	3	3	4	4	4	4
Material colour	4	4	4	4	4	4	4	2	2	4	4
Extraneous light	4	4	4	4	4	4	4	1	1	4	4
Measurement material	3	2	2	1	1	1	1	2	2	2	2
Electromagnetic radiation	2	2	2	1	1	2	2	3	3	2	3
Material velocity	3	3	3	2	2	0	0	3	3	2	3

Assessment of criteria according to VDI Guideline 2225:0 = unsatisfactory to 4 = optimum

Dr. Georg Kormann works in the department Ag. Management Solutions in the John Deere Werke Zweibrücken and is responsible for the development of a yield measurement system for self-propelled forage harvesters; John Deere Werke Zweibrücken, Homburger Str. 117, 66482 Zweibrücken; e-mail: KormannGeorg@JohnDeere.com
 Prof. Dr. Hermann Auernhammer is director of the specialist department Crop production Technology at the TU Munich, Am Staudengarten 2, 85350 Freising-Weißenstephan; e-mail: Auernhammer@tec.agrar.tu-muenchen.de

Keywords

Precision farming, moisture measurement, ingredients measurement, forage harvester

Literature

Literature information is available under LT 02523 via Internet at <http://www.landwirtschafts-verlag.com/landtech/local/fliteratur.htm>

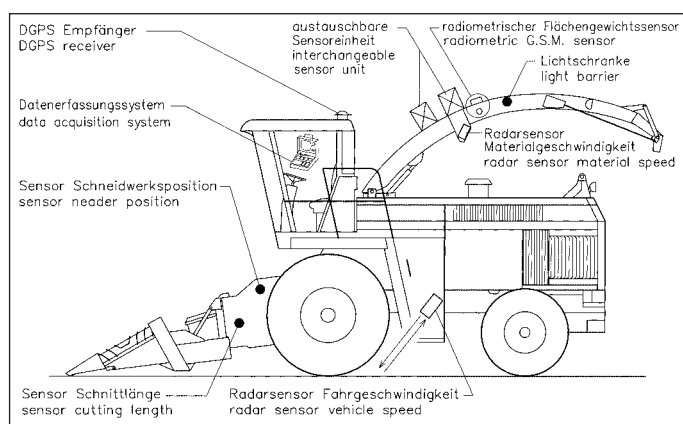

Fig. 1: Experimental set-up on a self-propelled forage harvester

ded ran between 8% and 85%. According to chop length, structure and moisture, material density varied between 0.05 kg/dm³ and 0.5 kg/dm³. The material flow in the harvester indicated a layer thickness of from 0 mm to 60 mm with a material velocity of 20 to 35 m/s. The theoretical investigation on suitability of moisture measurement systems for application on forage harvesters carried out with this information identified the near infrared reflection system as most suitable, followed by the microwave reflection system.

Within a four year period microwave reflection systems from Franz Ludwig, Hydronix and Strandberg Engineering, two microwave transmission systems from the companies Berthold and pro/M/tec, two capacitance systems from the companies Liebherr and Arnold and four near infrared reflection (NIR) systems from the firms Mesa, Perten, Zeiss and Rütter were all made available for basic investigations. In laboratory experiments these sensors were tested with material under measurement geometries predetermined by their manufacturers. The tests involved different harvest materials, layer thickness, densities and moisture contents. The reference measurements for moisture contents took place in a drying chamber where the sample was dried under 105 °C down to constant weight.

John Deere made available a 6950 forage harvester for the field trials. This machine was equipped with radiometric throughflow measurement system including radar sensor for material velocity, a DGPS receiver, a light beam, a cutting system sensor, a chop length sensor, a radar sensor for travelling speed and Caesar data recording equipment. The discharge spout additionally contained two exchangeable sensor modules that allowed the rapid fitting of different measurement sensors according to requirement (fig. 1).

While the drying chamber method was used in the laboratory tests for total sample testing for moisture, out in the field the taking and handling of a representative sample remains a problem even yet.

Results

The laboratory investigations clearly show which measurement system can be operated and the precision to expect along with the factors influencing results. The measurements with the microwave reflection and capacitance systems with their penetration depth of 60 mm to 100mm are very strongly layer dependent below these limits and additionally also density dependent, factors of influence which cannot be mathematically compensated for. The microwave transmission systems did not deliver a stable result and, according to manufacturer information, are not in the position to measure moisture at material velocities of over 6 m/s.

Contrary to this, the laboratory results of the NIR moisture sensors with standard deviations of less than 3% and coefficients of determination over 0.9, were very good. This measurement principle additionally allowed the recording of other components in the harvested material such as protein, starch or oil. A laboratory test with 69 samples of dried grass showed that the Perten DA7000 system is capable of determining protein with a precision coefficient of 0.979 and a standard deviation of 4.53% which represents an absolute deviation of ± 0.123%.

Sensor performance was similar in both field and laboratory trials. The results of the capacitance sensors proved to be very strongly influenced by layer-thickness and density, however. Additionally, measurement efficiency depended on the angle of the discharge spout in that the pressure on the material increased the lower the spout was positioned. Under these conditions, values varied within

a 10%-plus range at standard deviations of under 0.3. Compensation for the influence factors was not possible.

In mobile harvester application too, the NIR systems showed they could deliver very good results with their surface measurement and maximum penetration of 1mm when a representative amount of material was found. The Perten DA7000 delivered acceptable results for moisture, starch and protein contents (table 2). Should further components have to be exactly determined, more comprehensive field trials would have to be conducted.

The Zeiss Corona 45 NIR and the Mesa MM 710 NIR measurement systems delivered comparable results.

Discussion and conclusions

The investigations have clearly shown that only the NIR moisture measurement systems are applicable for use on the self-propelled forage harvester. An important requirement for reliable measurements is securing a good representative sample from the material flow. What is needed here from the quality control aspect is the development of an automatic sample taking system. Only then would the development of more robust calibrations be possible. Because of the high price of 10000 to 40000 € for the NIR sensors these can only be economically applied when other components are determined along with the moisture content. An exact investigation of the economic aspects of this measurement technique must follow.

The determination of material contents can then only be successfully carried out when the measurements produced are generally accepted. To this end, e.g., the development and distribution through an independent central position is necessary, as is currently the case with the German maize measurement network.

Table 2: Results from ingredients measurement by the Perten DA7000 system

Contents	Range [%]	R ²	SECV [%]	Factors
Moisture	57,4 - 68,6	0,774	1,39	13
Starch	28,0 - 41,2	0,608	1,62	13
Elos	63,8 - 75,9	0,449	1,69	16
Crude fibre	12,4 - 21,4	0,423	1,39	13
Crude protein	6,5 - 8,9	0,706	0,28	12
Ash	3,5 - 4,8	0,303	0,25	11
ME [MJ/kg]	10,0 - 11,5	0,348	0,23	9
NEL [MJ/kg]	5,9 - 7,0	0,360	0,17	9