

Bernhard Engelke, Kiel

Regulating possibilities in mechanical weeding

In organic farming the implement applied most for mechanical weeding in cereals is the weed harrow which mainly buries the weeds or in-part uproots them. Working depth and soil movement depend on soil properties and harrowing intensity (tine pressure and speed). Varying soil relationships, ground conditions and crop development means adopting a universal setting for the implement to suit the whole field can lead to insufficient weeding action and damage leading to yield penalties.

Applying weeding harrows to winter crops in spring with uniform field setting often results in too high tine pressure in sandy soil areas and subsequent crop damage. With clay soil areas the tine pressure can be too low giving poor weeding action. Spring cereal crops on clay soil develop more slowly in the early stages than when on lighter soils and are therefore more susceptible to mechanical damage. Harrowing intensity must therefore fit the conditions for good results with working speed and tine pressure alterable online to give optimum weeding action without yield penalties from damage (max. 10%) which includes plant and shoot reduction and the unearthing or injuring of roots through too deep work.

An automated weed harrowing system has been developed in Kiel with intensity adjustable to changing conditions. First trails have been conducted in winter and spring crops to determine correct harrowing intensity.

Determination of suitable harrowing intensities in winter and spring cereals

The trial findings can be summarised thus:

- The suitable intensity for black harrowing of winter cereals in spring varied only in relationship to soil consolidation and not crop development or density. Increasing soil consolidation required more intensity of harrowing, e.g. more tine pressure and less speed. For measuring ground consolidation in the upper soil layer – roughly the working depth – the construction of a soil sensor was required.
- The harrowing intensity to be applied on spring cereal crops didn't depend on the consolidation because seedbed preparation had consistently loosened the soil. It depended more on the growth stage of the crop which varied according to soil conditions. Crops in medium or light soil areas in early growth stages were further developed than on heavier soil because of the better soil/plant contact and faster soil warming-up. The best harrowing results were achieved when the intensity was increased up to the tolerance limit for cereal damage. For controlling this, reflection sensors capable of determining plant growth stage could be applied.

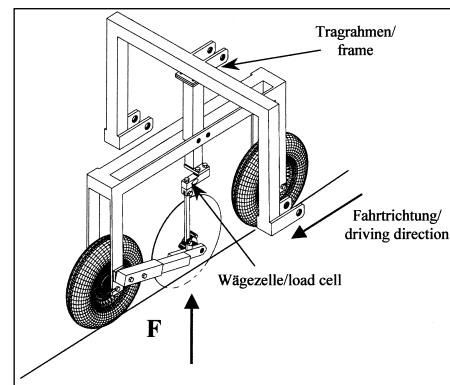

Fig. 1: Penetration sensor for continuous soil solidity acquisition

Soil sensor

The penetration force sensor was developed to determine soil consolidation. The sensor frame was fitted to the front power lift and the penetration resistance of the soil continually measured. Between the steering wheels of the sensor frame ran a 40 cm diameter disc coultter hung mounted on two attachment points. The 1280 Nr. weight of frame and lower links was distributed over frame tyres and disc coultter, the latter being run at a defined soil depth. The forces acting on the disc was measured by a weight cell.

Reflection sensors

The principle of reflection, the relationship of returned light to momentary radiation intensity enables the quantitative determination of green biomass through taking the relationship for both reflection degrees infrared (780 nm) to red (680 nm). The quotient or spectral index of infrared through red for soil lies at 1.1 to 1.4, for green plants at 6 to 15. As a result the IR/R index rises with increasing development of a cereal crop. The difference in the development at the first possible harrowing date on a heterogeneous field is between GS 12 and 16, later between 22 and 26. Development stage can be deduced from the measurable differences in the IR/R index (table 1).

Installation of automatic tine pressure adjustment

Using a 6 m working width Köckerling weeding harrow (4 harrow fields á 1.6 m)

Table 1: Growth Stage (GS) of wheat and IR/R-index

Harrowing date	Wheat-GS	IR/R-index
Early	13	1,5
	15	1,9
Late	22	4,0
	26	7,7

Bernhard Engelke is a member of the scientific staff at the Institute for Agricultural Procedural Technology, Christian Albrechts University (director: Prof. Dr. Edmund Isensee), Max-Eyth, Str. 6, 24118 Kiel; e-mail: b.engelke@ilv.uni-kiel.de

Keywords

Mechanical weed control, site specific, harrow intensity

with which tine pressure of the harrow fields which were parallelogram hung on the frame was adjusted via support wheel setting, an electronically adjusted aggregate was fitted instead of the adjusting spindles.

Tine intensity control system

Depending on whether soil consolidation or crop development is the decisive criteria on which harrowing intensity is based, the appropriate sensor and the harrows with tine pressure adjustment comprised the control system for

- Soil consolidation-harrowing intensity for winter crops, or
- Growth stages-harrowing intensity for spring crops (fig. 3).

The front lift sensor recorded either soil consolidation or the IR/R index from which the growth stage was deduced. Predetermined calibration then led to the calculation of required harrowing speed and tine pressure. The calibrating was field-specific and done by the farmer.

- In winter crops the soil consolidation was measured spatially by the soil sensor.
- In spring crops the IR/R index was spatially determined by the reflection sensors.

The spatially-suitable harrowing intensities were applied according to good management practice, from which calibrations were deduced.

The harrowing system was trialed in spring.

Spring crops: The reflection sensors clearly determined the soil condition related cereal crop development. The calibration was set for harrowing all spatial areas as intensively as possible so that the damage degree which would lead to yield depression was nearly reached but not quite exceeded. This allowed the weeds on all spatial areas to be tackled with maximum possible mechanical intensity.

Winter crops: Differences in soil consolidation occurring over the winter were efficiently recognised by the system on all fields. Through increasing tine pressure and reducing speed on consolidated areas such as

loam ridges, weed reduction was increased compared with results with universal setting. Reducing the tine pressure on lighter soil areas prevented the crop being subjected to unnecessary stress. An area example here is the measured soil consolidation of a winter wheat field with application of weed harrows in spring as presented in figure 4. Harrowing intensity on the shaded areas was intensified and reduced for the lighter areas.

Summary

For satisfactory harrowing results on all areas of a homogeneous field an automated harrowing system was developed. The harrowing intensity – speed and tine pressure – was adjusted to meet the variable conditions. In winter crops the intensity was according to soil consolidation level, in summer cereals, according to growth stage of the crop.

Literature

Books are identified by •

- [1] Böttger, W. und J. Kauke: Mechanisch Unkraut bekämpfen: Was ist realistisch? Pflanzenschutz-Praxis (1994), H. 4, S. 30-33
- [2] • Hartge, K. H. und R. Horn: Einführung in die Bodenphysik. Verlag Enke, 1999

- [3] • Reusch, S.: Entwicklung eines reflexionsoptischen Sensors zur Erfassung der Stickstoffversorgung landwirtschaftlicher Kulturpflanzen. Dissertation, Uni Kiel, 1997

- [4] Wildenhayn, M.: Getreide durch mechanische Unkrautbekämpfung geschädigt? Pflanzenschutz-Praxis (1993), H. 1, S. 12-15

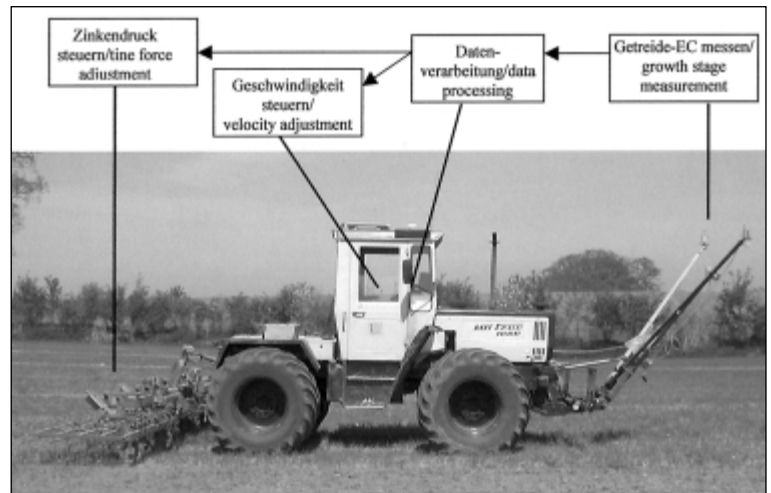

Fig. 3: Control-system Growth Stage-Harrow intensity

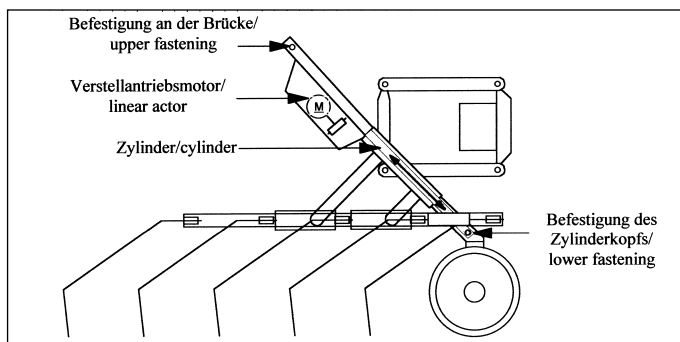

Fig. 2: Installed linear actuator to adjust the tine force

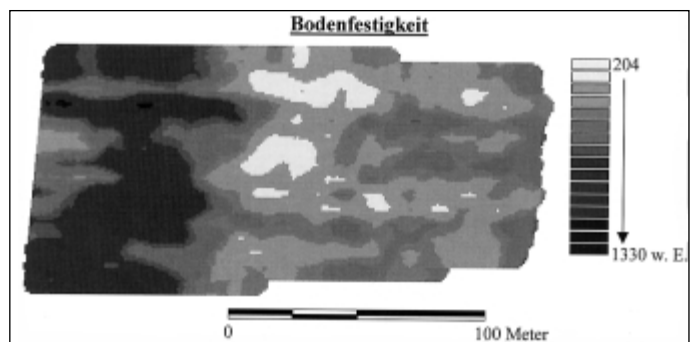

Fig. 4: Soil solidity